

SUMMATIVE ASSESSMENT - I (2012)

SCIENCE

CLASS - X

X-A

43

CHPS (IG)

M.M. 90

TIME : 3 Hrs.

General Instructions:

- i) The question paper comprises of two Sections, A and B. You are to attempt both the sections.
- ii) All questions are compulsory.
- iii) There is no overall choice. However, internal choice has been provided in all the five questions of five marks category. Only one option in such questions is to be attempted.
- iv) All questions of Section-A and all questions of Section-B are to be attempted separately.
- v) Question numbers 1 to 3 in Section-A are one mark questions. These are to be answered in one word or in one sentence.
- vi) Question numbers 4 to 7 in Sections-A are two marks questions. These are to be answered in about 30 words each.
- vii) Question numbers 8 to 19 in Section-A are three marks questions. These are to be answered in about 50 words each.
- viii) Question numbers 20 to 24 in Section-A are five marks questions. These are to be answered in about 70 words each.
- ix) Question numbers 25 to 42 in Section-B are multiple choice questions based on practical skills. Each question is a one mark question. You are to select one most appropriate response out of the four provided to you.

SECTION - A

- Q.1 In domestic electric circuit, with which wire do we connect a fuse? (1)
- Q.2 Name the two components of central nervous systems in humans. (1)
- Q.3 Name one fuel used in nuclear reactor. (1)
- Q.4 Barium chloride reacts with aluminium sulphate to give, Aluminium chloride and Barium sulphate. (2)
- i) State the two types in which the above reaction can be classified
 - ii) Translate the above statement into a chemical equation.
- Q.5 Name two metals that start floating after some time when immersed in water and explain why they do so? (2)
- Q.6 A battery of 12 V is connected to a series combination of resistors, 3Ω , 4Ω , 5Ω , and 12Ω . How much current would flow through the 12Ω resistor? (2)
- Q.7 Why do two magnetic field lines never intersect each other? (2)

- Q.8 In the electrolysis of water: (3)
- Name the gas collected at the cathode and anode respectively
 - Why is the volume of one gas collected at one electrode double that at the other? Name this gas.
 - How will you test the evolved gases?
- Q.9 A metal 'X' acquires a green colour coating on its surface on exposure to air. (3)
- Identify the metal 'X' and name the process responsible for this change.
 - Name and write chemical formula of the green coating formed on the metal
 - List two important methods to prevent the process.
- Q.10i) What is meant by the term hydrated salt? (3)
- Give two examples of hydrated salt which are white and state their chemical formula.
- Q.11 Define alloys? List the properties of alloys that makes them useful over pure metals? Explain this fact with suitable examples. (3)
- Q.12i) Calculate the electrical energy consumed by a 1200 W toaster in 30 minutes. (3)
- What will be the cost of using the same for 1 month if one unit of electricity costs Rs 4./
- Q.13 State any two factors on which the resistance of a cylindrical conductor depends. Compare the resistance of a conductor of length 'l' and area of cross section 'a' with that of another conductor of same material but of length and area of cross section half and double respectively of the former. (3)
- Q.14 What is a solenoid? Draw a diagram to show the magnetic field lines around a current carrying solenoid. Mention two ways to increase the strength of the field of a solenoid. (3)
- Q.15 List in tabular form, three differences between arteries and veins. (3)
- Q.16 State the functions of plant hormones? Name four different types of plant hormones. (3)
- Q.17a) Draw the structure of neuron and label cell body and axon. (3)
- Name the part of neuron:
 - Where information is acquired
 - through which information travels as an electrical impulse.
- Q.18 Explain the principle and working of a biogas plant using a labelled schematic diagram. (3)
- Q.19 Explain ocean - thermal energy and how can it be harnessd. Mention any two limitations in obtaining the energy from the oceans?
- Q.20a) Which method will you use to reduce the following? Explain by giving a suitable example.
 - Oxides of less reactive metals
 - Oxides of moderately reactive metals

- iii) Oxides of highly reactive metals
- b) The reaction between metal 'X' and Fe_2O_3 is highly exothermic and is used to join railway tracks. (3)
- i) Identify metal 'X' and name the reaction
- ii) Write the chemical equation of its reaction with Fe_2O_3

OR

- i) Write the electron-dot structures for sodium (11), oxygen (8), chlorine (17) and Magnesium (12) [Number given in parenthesis atomic number of element] Show the formation of Na_2O and MgO by the transfer of electrons.
- ii) Name the ions present in these compounds?
- Q.21 A student dropped few pieces of marble in dilute hydrochloric acid, contained in a test-tube. The evolved gas was then passed through lime water. (5)

What change would be observed in lime water?

What will happen if excess of gas is passed through lime water?

With the help of balanced chemical equations for all the changes explain the observations.

OR

- a) Five solutions A, B, C, D and E when tested with universal indicator showed pH as 4, 1, 11, 7 and 9 respectively. Which solutions is:
- i) neutral
- ii) strongly alkaline
- iii) strongly acidic
- iv) weakly acidic and
- v) weakly alkaline

Arrange the solutions in increasing order of H-ion concentration

- b) Name the acid and base from which the following salts have been formed,
- i) Sodium acetate
- ii) Ammonium chloride

- Q.22 Find out the following in the electric circuit given in the figure. (5)

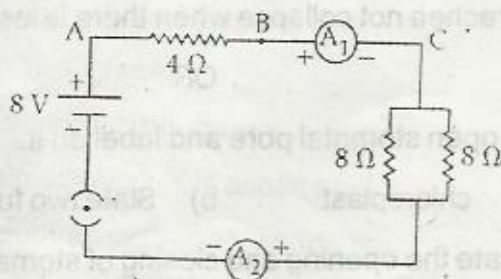

{X-3}

- a) Effective resistance of two $8/\Omega$ resistors in the combination
- b) Current flowing through 4Ω resistor
- c) Potential difference across 4Ω resistor
- d) Power dissipated in 4Ω resistor
- e) Difference in readings of ammeter A_1 and A_2 if any

OR

- a) State ohm's law.
- b) Draw a circuit diagram for the verification of Ohm's law.
- c) The potential difference between the terminals of an electric heater is 60 V when it draws current of 4 A from the source. What current will the heater draw if the potential difference is increased to 120 V.

Q.23 Describe briefly an activity to : (5)

- i) demonstrate the pattern of magnetic field lines around a straight current carrying conductor and
- ii) find the direction of magnetic field produced for a given direction of current in the conductor. Name and state the rule to find the direction of magnetic field around a straight current carrying conductor. Draw a diagram to explain the same activity.

OR

- a) Name and state the rule to determine the direction of a
 - i) Force experienced by a current carrying straight conductor placed in a magnetic field which is perpendicular to it.
 - ii) Magnetic field produced around a current carrying circular loop.
 - iii) Current induced in a coil due to its rotation in a magnetic field.
- b) Explain the function of an earth wire ? Why is it necessary to earth metallic appliances?

Q.24a) Draw a diagram of human respiratory system and label on it: (5)

- i) larynx ii) trachea iii) lungs iv) bronchi
- b) Why do the walls of the trachea not collapse when there is less air in it?

OR

- a) Draw a diagram to show open stomatal pore and label on it:
 - i) guard cells ii) chloroplast b) State two functions of stomata.
- c) How do guard cells regulate the opening and closing of stomatal pore?

SECTION - B

- Q.25 During the experiment of heating of Ferrous sulphate crystals, four students recorded their observations as : (1)
- green colour, of crystals changes to brown black colour
 - brownish yellow gas is evolved
 - blue colour of crystals changes to green colour
 - smell of burning sulphur is felt

Which of the above observations are correct?

- a) (i), (ii) b) (i), (iv) c) (ii), (iii) d) (iii), (iv)
- Q.26 An iron nail is placed in a solution of copper sulphate. The nail is taken out after 10 minutes. The nail will be found to be covered with (1)
- a) brown deposit b) black deposit
c) white deposit d) gray deposit

- Q.27 A dilute solution of sodium bicarbonate is taken in a test tube and a few drops of the universal indicator is added to it.

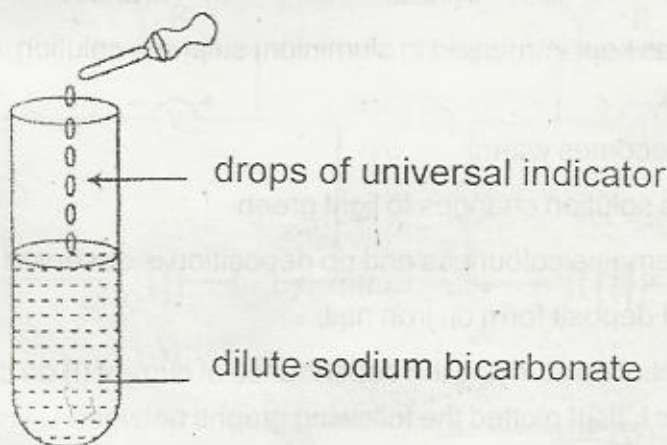

The colour observed will be :

- a) blue b) yellow c) orange d) green

- Q.28 A student dips pH papers in solution X and Y and observes that the pH paper turns blue and orange respectively in them. He infers that:
- X is HCl solution, Y is NaOH solution
 - X is acetic acid, Y is sodium carbonate solution
 - X is sodium carbonate solution, Y is acetic acid
 - X is oxalic acid, Y is sodium carbonate solution

Q.29 On bringing a lighted match stick near the mouth of the test - tube in which NaOH and Zn react:

- a) the matchstick gets extinguished
- b) the matchstick burns faster
- c) a pop sound is heard
- d) no effect is observed on matchstick

Q.30 Four test tubes containing solution of different colour marked I, II, III and IV are shown below. The test tubes containing copper sulphate solution and Ferrous sulphate solution, could be the tubes:

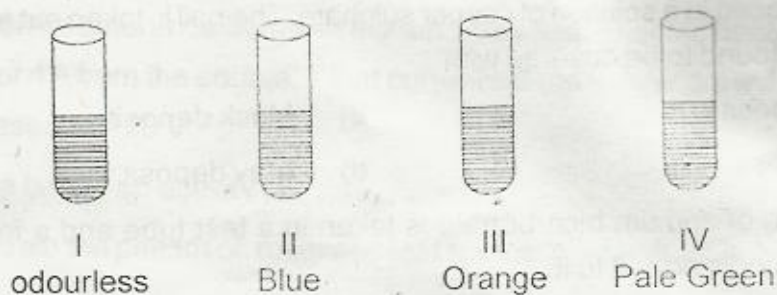

- a) I and II
- b) II and III
- c) III and IV
- d) II and IV

Q.31 An iron nail was kept immersed in aluminium sulphate solution. After about an hour, it was observed that:

- a) the solution becomes warm
- b) the colourless solution changes to light green
- c) the solution remains colourless and no deposition is observed on iron nail.
- d) grey coloured deposit form on iron nail.

Q.32 In the experiment on studying the dependence of current (I) on the potential difference (V), three students I, II, III plotted the following graphs between V and I. The graph that is likely to be correct is / are: (1)

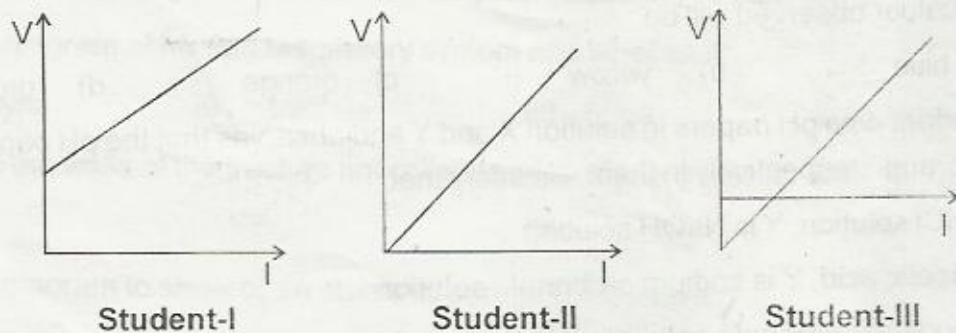

- a) I only
- b) II only
- c) III only
- d) all the three students

- Q.33 The current flowing through a resistor connected in an electric circuit and the potential difference developed across the ends of it are as show in the diagrams.

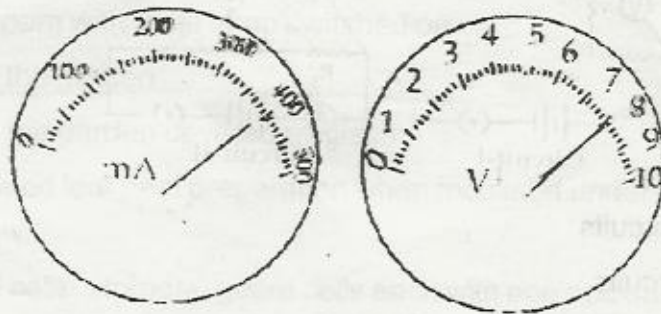

The value of the resistance of the resistor is :

- a) 20Ω b) 0.024Ω c) 24Ω d) 0.020Ω
- Q.34 The correct set up for studying the dependence of the current on the potential difference across a resistor is :

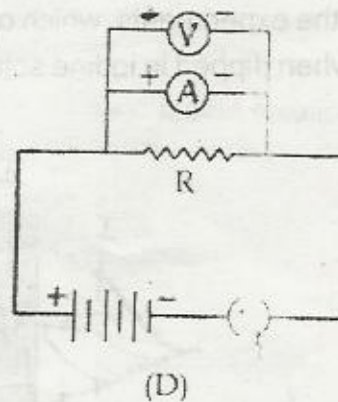
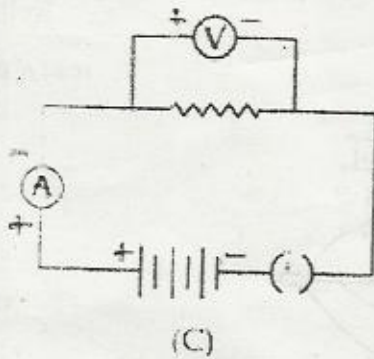
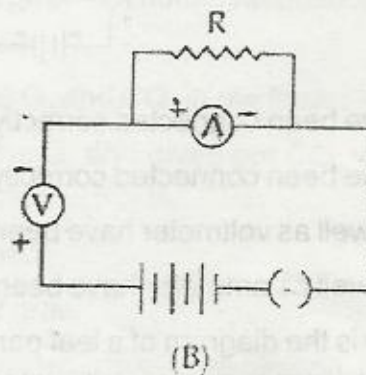
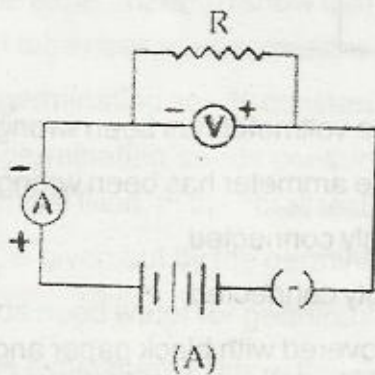

- a) A b) B c) C d) D

Q.35 In the circuit given below. The resistors R_1 and R_2 are connected:

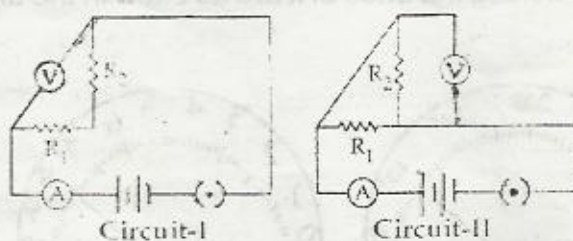

- a) in parallel in both circuits
 b) in series in both circuits
 c) in parallel in circuit I and series in circuit II
 d) in series in circuit I and parallel in circuit II
36. A student set up electric circuit shown here for finding the equivalent resistance of two resistors in series. In this circuit.

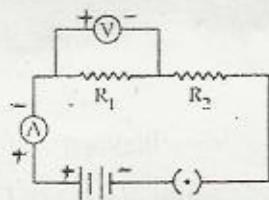

- a) resistors have been connected correctly but the voltmeter has been wrongly connected.
 b) resistors have been connected correctly but the ammeter has been wrongly connected.
 c) resistors as well as voltmeter have been wrongly connected.
 d) resistors as well as ammeter have been wrongly connected.
- Q.37 Given below is the diagram of a leaf partially covered with black paper and which is to be used in the experiment to show that light is necessary for the process of photosynthesis. At the end of the experiments, which one of the leaf parts labelled I, II and III will become blue - black when dipped in iodine solution?

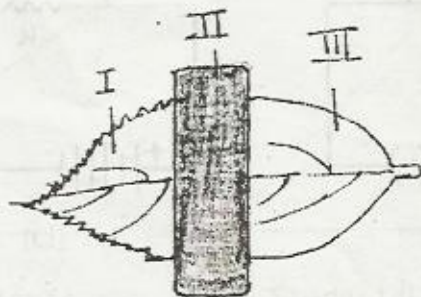

- a) I only b) II only c) I and III d) II and III

- Q.38 The best result for the experiment that light is necessary for photosynthesis be yielded by using leaves from a plant kept for over twenty - four hours:
- in a pitch dark room
 - in a dark room with table lamp switched on
 - outside in the garden
 - outside in the garden covered by glass
- Q.39 A well stained leaf peel preparation when focussed under high power of the microscope would show:
- epidermal cells, stomata, guard cells each with one nucleus and many chloroplasts
 - epidermal cells, stomata, guard cells each with many nuclei and one chloroplast
 - stomata and guard cells without nuclei or chloroplasts
 - stomata but no guard cells or epidermal cells
- Q.40 Stomata plays an important role in :
- respiration
 - transpiration
 - photosynthesis
 - (d) all of the above
- Q.41 In the experiment 'To show that CO_2 is given out during respiration', the water level in the bent tube rises after sometime because:
- the germinating seeds consume all the O_2 and CO_2 in the flask.
 - the germinating seeds consume all the O_2 and gives out CO_2 which is absorbed by a chemical filled, in the small test tube.
 - CO_2 is given out by the germinating seeds.
 - seeds need water for germination and grow.
- Q.42 In the experiment to show that CO_2 is given out during respiration, the chemical filled in the small test tube is :
- alcohol
 - lime water
 - KOH
 - iodine solution